

FOOD PROCESSING SOLUTIONS

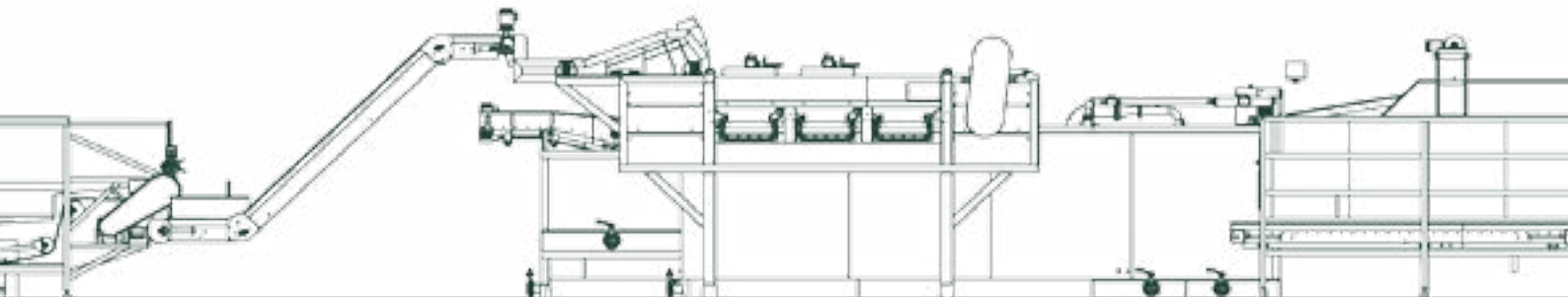



Fresh market

Constructie Bruynooghe is a well-known name when it comes to machines or processing lines for the fresh market (carrots, root vegetables, ...).

From **the reception** of the products until they are completely cleaned: **desanding, destoning, washing, ...**

After that, they **get sorted** by shape and colour so they **can be packed** in any way possible or supplied to the processing industry.

Constructie Bruynooghe has a wide range of standard and customized machines from which these production lines can be built.

● Reception:

■ Dry or wet reception hoppers / box tippers / desanders / destoners / conveyor belts / ...

● Cleaning/Treatment:

■ Washers / brush washers / weed removers / shakers for length grading / hydrocoolers / water flumes / cutting machines / ...

● Sorting/Storage:

■ Rollergraders / sorting shakers / storage hoppers / ...

● Waste removal:

■ Screws / conveyor belts / static and rotary filter systems / ...

Manual inspection



Hydrocooler

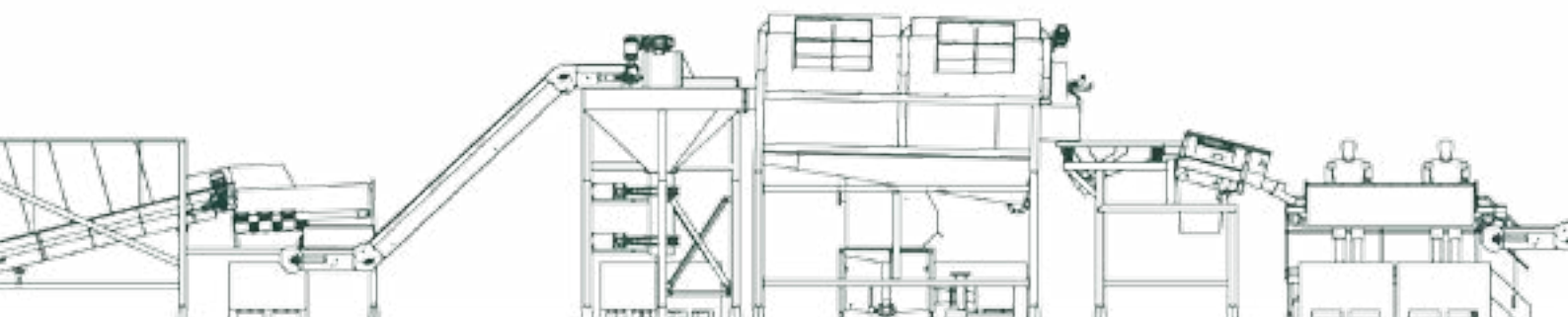



Industry / pre-treatment

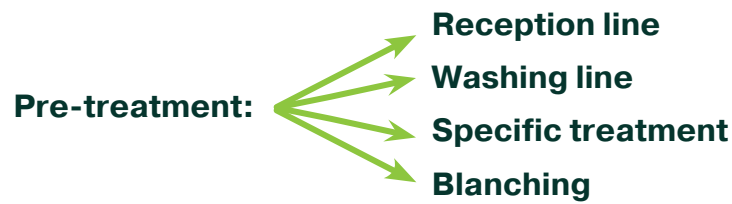

Constructie Bruynooghe also has lots of experience when it comes to **industrial processing** of vegetables.

Here too, it starts with **the reception** of the products, **cleaning** and **washing** them.

After this they can undergo **specific treatments** such as **cutting, (pre)snipping, (steam) peeling, sorting, ...** The treatments used depend on the type of vegetable and the desired end product.

Finally, the products **are blanched** in order to preserve the maximum flavour and nutritional value.

Blanching is an important step in the industrial processing of vegetables and fruit.

Constructie Bruynooghe has different machines in its product range for blanching vegetables and fruit, each with its own advantages.

That is why Constructie Bruynooghe makes both **drum blanchers** and **belt blanchers**. This takes into account the customer's requirements for energy and water consumption, hygiene and usability.

Washing line for spinach



Bean line



Belt blancher

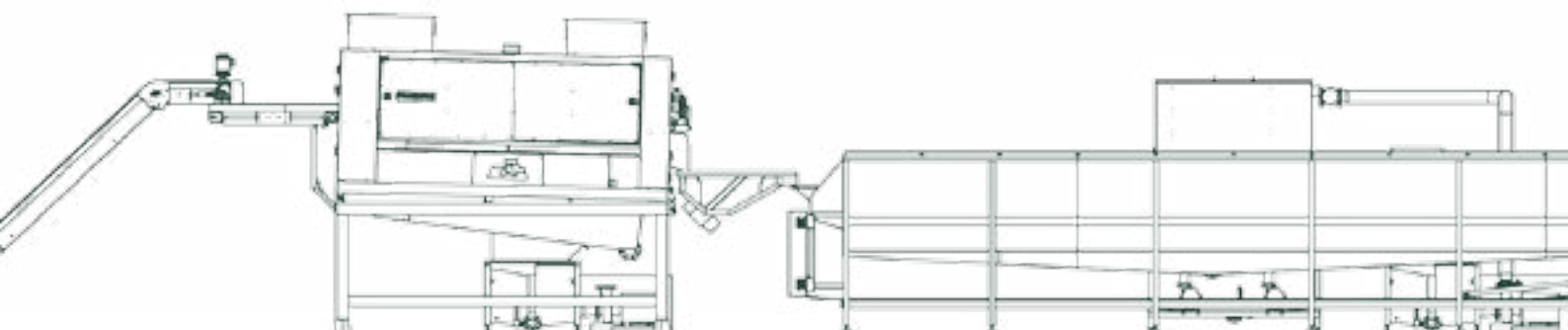



Industry / post-treatment

Frozen and prepared foods

After the blanching process, the products are deep frozen as quickly as possible to guarantee their freshness.

After freezing, the products are processed further on **conditioning lines** before being packed. Constructie Bruynooghe has years of experience in making machines and the installation of production lines to treat frozen foods.

To start with, the product is tipped from the storage package into a bunker with an extraction system, in order to keep the flow as even as possible.

Subsequently, numerous processes can happen during this continuous production flow: sorting by size, optical sorting, metal detecting, glazing, ...

Finally, the product **is dosed** in such a way that the weighing and packing machine can do its job perfectly.

Mixing frozen foods is one of Constructie Bruynooghe's specialities.

Complete mixing lines are built with the utmost attention to accuracy, accessibility for cleaning and usability.

Mixing lines that meet the latest requirements with regard to allergens are also possible.

Mixing line



Packing line

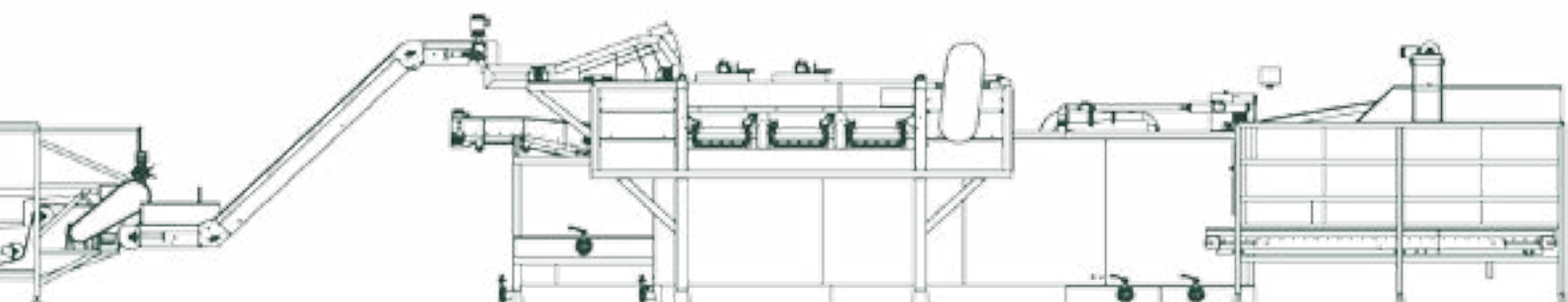



Other products

● Hard fruit

● Pasta

● Olives

In addition to production lines for processing vegetables, Constructie Bruynooghe also manufactures:

- Reception and infeed lines for hard fruit.
- Cooking and cooling lines for pasta and rice.
- Processing lines for olives.

● Rice & cereals

● Meat

● Tobacco

■ All kinds of stainless steel machines also usable outside of the food industry.

■ Filter installations for the treatment of waste water (static filters, filter drums, screws...).

Cooking and cooling line for pasta



Storage and dosing systems

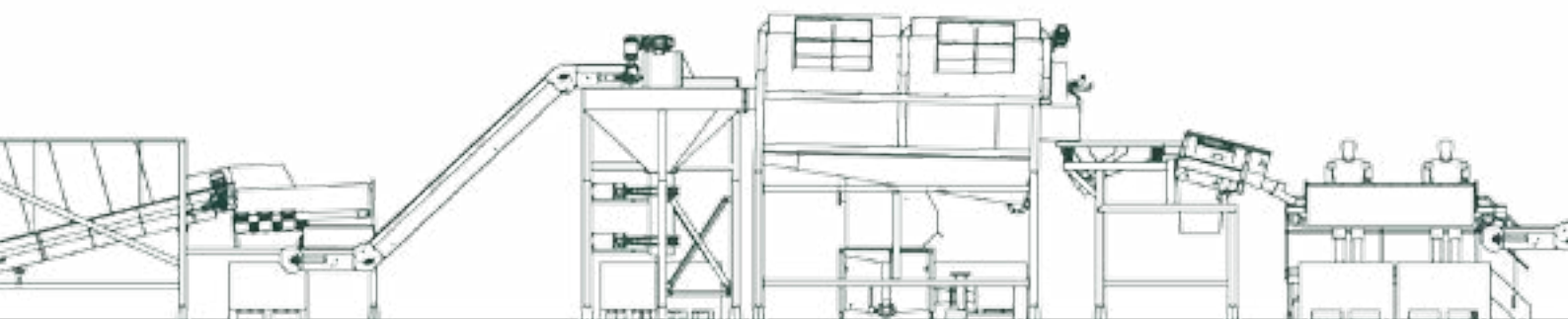



3D design



Construction/welding



Laser

Constructie Bruynooghe N.V.

Constructie Bruynooghe is an internationally well-known name when it comes to processing machines for the fresh market and industrial processing within the food industry.

Constructie Bruynooghe machines guarantee **solidity** and **reliability**, all the way from reception of the products through to packing.

The complete processing lines are discussed in detail with the customer and customized according to the product and the capacity requested. The machines are designed **in 3D** and then carefully produced in Constructie Bruynooghe's workshops.

Constructie Bruynooghe organizes the transport **worldwide** and assembles the processing lines on site with the utmost care. This includes not only the machinery but also the water circuit and the automation – **“ a turn-key solution ”** that undoubtedly offers additional value to the customer.



● **Constructie Bruynooghe n.v.**
Bruggestraat 74
8840 Staden
Belgium
Tel.: +32 51 70 50 88
Fax.: +32 51 70 51 40
sales@bruynooghe.be
www.bruynooghe.be

